

Chicago Botanic Garden
Institute of Museum and Library Services
National Leadership Grants
PlantCollections

1. Assessment of Need

Persistent and growing threats to biodiversity have created a mandate for museums with significant biological collections to re-evaluate how they make their collections and collections data available to audiences, both public and scientific (Alberch, 1993, Dalton 1999, Dunn 2002). As significant repositories of living plant germplasm (plants and seeds), botanic gardens and arboreta are in the vanguard of plant biodiversity preservation. Equally important is the information collected and stored at each of these institutions regarding their living collections. Currently, the inaccessibility of this data undermines the study and understanding of complex biological relationships in the environment. This lack of understanding in turn dooms mitigating efforts towards the preservation of biodiversity and may speed extinction of species. The sense of urgency for information is intensified by the fact that 30 percent of plant species in the United States face extinction within the next 50 years, according to the IUCN: World Conservation Union. Our nation's flora is the fourth most endangered in the world, and yet the number of nationally or internationally endangered plants growing in botanic garden collections is unknown. Institutions with living collections must work in unison to best preserve our biological heritage.

Living plant collections at numerous botanical gardens and arboreta around the United States provide an important resource for scientific and education communities, commercial plant breeders, restoration stewards, and the visiting public. Each garden's collection typically specializes in a particular biogeographic region or focuses on a taxonomic group of plants. These collections and data can provide a wealth of information and genetic resources to both local and national communities. Combining the information from collections over diverse regions and data sets provides an extensive resource for diverse audiences, as well as the foundation of a national infrastructure for accessing and sharing information among botanical gardens and arboreta.

To coordinate and improve living plant collections and enhance the conservation and availability of plant germplasm for current and future use, the American Association of Botanical Gardens and Arboreta (AABGA) created the North American Plant Collections Consortium (NAPCC) in 1992. Membership in the NAPCC requires a comprehensive collection of a particular taxonomic group or geographic flora, with a written management plan detailing how to preserve the collection indefinitely. NAPCC members provide for curatorial and documentation activities and make the genetic resources available to a wide scientific audience. Today the NAPCC institutions hold many of the highest quality living plant collections representing taxa of known wild origin as well as cultivar collections (plants of cultivated origin) of cultural and historic significance. Each of these institutions will share not only their NAPCC collections, but also all of their accessioned plants, creating a resource of much greater value.

The fundamental need for a database linking application that can be queried collectively and produce collated reports is recognized by NAPCC curators and scientists nationwide. In

fact, a September 2004 NAPCC task force report quoted Dr. Peter Raven, director of the Missouri Botanical Garden, as saying

“...[NAPCC] need[s] to develop an efficient computer-based system for recording the holdings of the gardens, and preferably the gardens throughout the world. Without knowing who has what...the maintenance and assembly of collections cannot be efficient, and in fact most of what botanical gardens do is wasted or replicated effort, unknown to others, and not generally available.”

Audiences

The potential national audiences for a database linking application can be inferred from current informational requests to the plant records departments of the cooperative institutions. These audiences include curators, taxonomists, horticulturists, conservationists, ecologists, and weed scientists, as well as educational communities and the visiting public. Table 1 outlines the audience and the potential benefit of access to a linked database network.

Table 1.

| Audience | Benefit |
|---|---|
| Curatorial: (Est. 500) | Access to information about plant collections is directly tied to plant curators' job responsibilities of researching and selecting plants for botanic gardens and arboreta. |
| Taxonomy: (Est. 100) | Systematic research on the relationships of plant taxa depends on access to plants or plant DNA samples, notably of plants with known and varying provenances. A linked database will greatly facilitate the location of such specimens. |
| Conservation (Est. 500) | <i>Ex situ</i> conservation is based upon plants in cultivation. If conservationists can identify populations already in cultivation, the pressure of additional seed harvests from remaining wild populations will be diminished. Crucial natural collections not in cultivation can also be identified and prioritized for conservation. A linked database will help identify threatened or endangered plants held in collections as well as those that are not represented in cultivation. |
| Weed Science: (Est. 1,000) | Most botanic gardens have held non-native plants in their collections for many years. A database linking application will help identify plants that have been shown to be pre-disposed to invasiveness in a particular climate or region. |
| Ecology: (Est. 250) | Many botanic gardens and arboreta manage natural areas on their institutional grounds. These well-documented collections of native taxa are ideal for the study and dissemination of natural ecosystem processes while also serving as reservoirs of regional biodiversity. |
| Horticulture: (Est. 3,000 – 5,000) | The ongoing search for new and improved plants for landscape uses is a response to changing climactic pressures as well as evolving landscape aesthetics. A comprehensive database can help identify plants with broad landscape applicability, new plants for cultural use, and germplasm for plant improvement programs. Pooled information can also deter the practice of recollecting germplasm from the wild, if it can be shown to exist in another collection. |
| Education: (Est. 3,000 – 5,000) | <i>PlantCollections</i> will contribute to educating the next generation of plant scientists and environmental stewards with an easily accessed data that could be used by students from middle school to graduate school. |
| Visitors: In 2002, 5,760,450 in just 10 gardens | Visitors are the ultimate beneficiaries whenever botanic gardens and arboreta improve their collections management, conservation, and diversity. <i>PlantCollections</i> provides a critical tool for this activity in the 21 st century. |

Currently, curators and scientists search for plants or plant records data by contacting individual plant records staff at peer institutions. The process is cumbersome and time-consuming. As seen above, many different audiences would benefit from an efficient, direct-service database that would provide timely access to information on existing North American plant collections.

Limiting Factors

Several factors have prevented a creation of a national database linking application, including technological disparities between interested institutions and lack of institutional resources. Currently within NAPCC's membership of 23 institutions, nine different collections management software applications or versions of applications are employed. While most institutions do not offer their inventories on the internet, those that do use different formats and taxonomic names. Past attempts to electronically transmit data between NAPCC members or to share data outside the NAPCC institutions have proven cumbersome, expensive and time consuming due to the heterogeneous nature of the database software applications and data formats. But there is a growing interest and appreciation for the possibility of sharing data between institutions, especially as it relates to core programs of curating collections and *ex situ* conservation, especially at a time when technological advances (both hardware and software) make such data sharing more feasible.

2. National Impact and Intended Results

The Chicago Botanic Garden, in collaboration with the American Association of Botanical Gardens and Arboreta, will develop *PlantCollections* to bring into circulation the existing knowledge of living plants as represented in the documented records of botanic gardens and arboreta. Its long-term impact will be to significantly improve the primary activity of botanic gardens and arboreta: collecting, studying, and conserving living plants.

PlantCollections will notably improve the process of collecting plants and address conservation issues, whether *in situ* or *ex situ*. Utilizing a database linking application, curators and scientists nationwide can quickly locate extant germplasm that easily may be obtained, thus preventing unnecessary expeditions and disruption of plants *in situ*. Conversely, a database linking application can help identify endangered or threatened plant species whose germplasm should be conserved *ex situ*. A recent study in the United Kingdom identified an estimated 9,000 species that are threatened worldwide but thriving in botanic gardens.

The Chicago Botanic Garden recognizes the internet's potential for data sharing and dissemination. The Garden has been involved with or spearheaded such IMLS-funded web-based projects as: the Center for Plant Conservation's National Collection of Endangered Plants; *vPlants* (Shaub and Dunn 2002), a virtual herbarium project with The Morton Arboretum and The Field Museum; *ePlants* that makes available the Garden's plant evaluation notes on best plants for the Upper Midwest climate; as well as *Illinois' Best Plants*. These projects are valuable for conservation scientists, horticulturists, and education. Critically missing has been a national system for searching, accessing, and exchanging information among botanic gardens and arboreta living collections. The Chicago Botanic Garden is well positioned to lead such a project.

Solution

AABGA conducted a survey of technology options to determine the best application for a database linking application that would connect the many divergent systems used by NAPCC members (See Attachments). This survey identified the Distributed Generic Information Retrieval (DiGIR) system, developed by the Biodiversity Research Center at the University of Kansas (KU), as the optimum method to link institutions, owing to its relative simplicity and economy.

Distributed information retrieval systems have been successful in the bibliographic and museum community and have been adapted to work effectively with biological domains such as natural history collections (speciesanalyst.net). Significant protocol shortcomings, when applied to biological communities, prompted the development of a new protocol—DiGIR (Distributed Generic Information Retrieval, <http://digir.net>). DiGIR uses a much simpler technical foundation for data transfer and XML-Schema-based translation of federation schemas. DiGIR is open source software available at no cost through Source Forge and possesses a robust, active user community support and support for upgrades. The DiGIR application is illustrated in the schematic below.

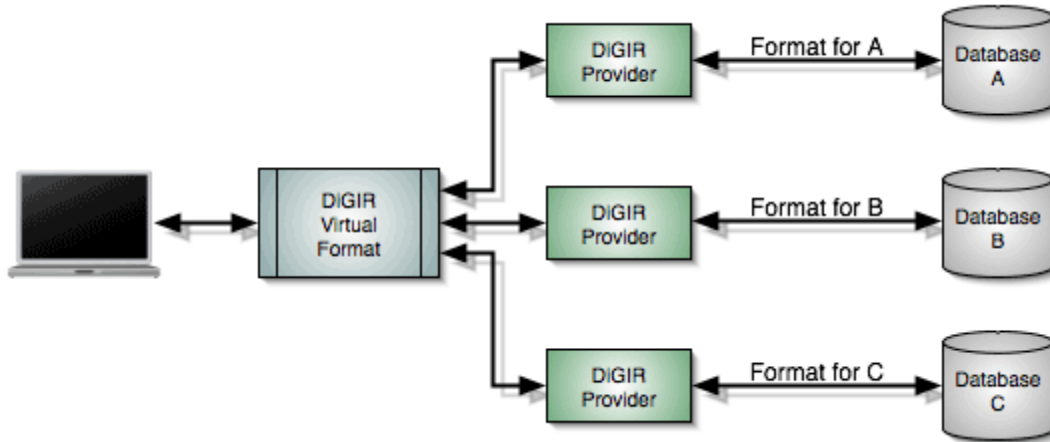

Since its inception, DiGIR has been used globally on a number of biodiversity related projects such as collection records from natural history museums. Projects using DiGIR protocol or converting to DiGIR protocol include: FishNet; The Mammal Networked Information System (MaNIS); HerpNet – Reptiles and Amphibians; The Ornithological Information System (ORNIS) – Birds; The Integrated Taxonomic Information System (ITIS). Barbara R. Stein and John Wiczorek (Museum of Vertebrate Zoology, University of California Berkeley) noted:

“The simplicity of the network’s design ensures that any institution wishing to join MaNIS may do so at relatively little cost and with relatively little technical expertise. Although development of MaNIS and its underlying architecture relied on a number of key programming tasks and innovations, much of what the project can offer at this pivotal juncture is insight into its approach and a template by which other disciplines can engage in a similar process with equal success.” *Biodiversity Informatics*, 1, 2004.

The Chicago Botanic Garden and AABGA will work with KU’s Biodiversity Research Center to adapt the DiGIR software to achieve similar functionality and access to shared data resources held by living plant collections nationwide. This project will begin the process of linking the plant records documentation of plant collections among AABGA’s 490 institutional members nationwide by first linking the datasets from 16 institutions with broad yet diverse collections.

Addressing the challenge will:

1. **Enable collaborative research** by using the technology and collaboration framework to develop and deploy *PlantCollections*, a powerful distributed community information network of almost 47,100 plant taxa from 16 North American botanical gardens and arboreta. *PlantCollections* will enable research into complex biodiversity phenomena that previously were intractable. In effect, *PlantCollections* will create a new computational biodiversity research community (Krishtalka & Humphrey, 2000; Pennisi, 2000).
2. **Improve plant collections management and conservation** by identifying existing plant collections and determining vacancies in collections.

3. **Contribute to educating** the next generation of plant, conservation, and biodiversity informatic scientists and provide the public with the results of knowledge networking of botanical biodiversity information.
4. **Advance technology** by deploying a standards-based informatics and collaboration architecture for coordinated authorship, access, integration and use of biodiversity data in research, natural resource management, and education across biotic, earth systems science and computational domains. Specifically, *PlantCollections* will employ a distributed query architecture for retrieval and integration of biodiversity data associated with the collections records of living plants held at botanical gardens and arboreta.

The *PlantCollections* project represents a fundamental link to information that will have applications for multiple audiences, nationally and internationally. Interoperability of databases and a nationwide reach are primary objectives. Beginning with a small group of botanic gardens and arboreta, the project will lay the groundwork for all interested AABGA institutions with living plant collections.

3. Project Design and Evaluation Plan

The Chicago Botanic Garden and the AABGA will work with the Biodiversity Research Center (BRC) at the University of Kansas to develop *PlantCollections*. The project's goal is to bring into currency—for science, education, and society—an accumulated knowledge of plants, held in North American botanic gardens and arboreta. The 23 members of the North American Plant Collections Consortium (NAPCC) have been asked to join the project, and 16 institutions have committed their staff and institutional resources over three years.

Project objectives include:

- Develop a “federation schema” for representing information held in botanical gardens and arboreta, and where possible, reuse existing concepts and data types.
- Install DiGIR data providers at all participating institutions to provide a consistent information retrieval interface to their collections databases.
- Install at least one (and optimally one per participating institution) portal for accessing these data through the internet.
- Establish a training protocol so that new participants can maintain the DiGIR application system.
- Strengthen the relationships between the participating institutions and foster the further sharing of information between members of the community and the public.

A Community Solution

Collection data from a single museum or archive rarely contain enough information for comprehensive analyses of an evolutionary lineage, geographic region, or environmental conditions. By pooling and integrating massive, dispersed collections data through information technology, *PlantCollections* will bring these data into service for research,

education, and public policy. Moreover, the network achieves dramatic economies of scale because it represents a coordinated, collaborative effort among many institutions, rather than a single-investigator or single-institution project. *PlantCollections* is a coordinated community project that none of the participating institutions could implement or finance on their own.

In addition, distributed community systems offer powerful advantages to centralized ones:

- Each participating institution retains control of its data resource.
- Data updates are dynamic, because they are maintained (i.e., updated, edited, and supplemented) individually across the institutions that house the primary documentation, data and voucher specimens.
- The entire network is not dependent on any single resource. If a node fails, only its content becomes temporarily unavailable; the rest of the network keeps functioning.
- Distributed community systems are less expensive to maintain because they are not dependent upon creating and maintaining an extremely large database (potentially 300,000 living plant taxa)

Application of DiGIR to this community requires the following key steps to be followed:

1. Define the federation schema and metadata requirements for the community.
2. Implement any software changes required for full support of the data sharing goals of this community.
3. Install and configure data provider hardware and software at participating institutions.
4. Install and configure the data portal (web site access) at sites that will act as data portals.
5. Test system throughout implementation and make improvements as necessary.
6. Advertise and promote the deployed network.

Phase I

PlantCollections will be developed in two phases over three years. The first phase will involve a small group of NAPCC participants, representative of the larger botanic garden and arboreta community. Participants will include institutions with different database applications and information technology capacities. The intention is to identify and address the various issues within a small group before extending the technology to the larger community. Test questions are: 1) Can the DiGIR application be modified for use by the living plant collections community? and 2) Can DiGIR be satisfactorily adapted to the database applications?

The following institutions have committed to participating as Phase I partners; all are members of AABGA and the North American Plant Collections Consortium.

Table 2.

| Institution | Location | Size (Opr. Budget)* | Database | Tech. Support Level |
|--|-------------------|---------------------|-------------|---------------------|
| Chicago Botanic Garden | Glencoe, IL | Large | Access 97 | Strong |
| The Huntington Library, Museum, and Botanic Garden | San Marina, CA | Large | BG-Base 6.4 | Strong |
| Ganna Walska Lotusland | Santa Barbara, CA | Mid-Size | Access 2000 | Medium, contractor |

| | | | | |
|----------------------------------|----------------|-------|-------------|--------------------|
| The Missouri Botanical Garden | St. Louis, MO | Large | Access | Strong |
| The Morton Arboretum | Lisle, IL | Large | PICK | Strong |
| Mt. Cuba Center, Inc. | Greenville, DE | Large | BG-Base 6.4 | Medium, contractor |
| United States National Arboretum | Washington, DC | Large | BG-Base 6.4 | Strong |

*Annual operating budget key: Large >\$2 million; Mid-size between \$1-2 million;

Federation Schema

A federation schema is the common language—the definition of information resources, shared between participating information providers. As such it acts as the glue that binds together the members of an information community. Federation schemas, as used in the DiGIR protocol, can inherit concepts from other schemas, and so form the basis for information sharing both within a community and between different communities that share common concepts.

The first Phase I task is to develop a federation schema that suits the information sharing requirements of the living plant collections community. This necessitates a consensus between key participants and a formal mechanism for design of the schema.

The Chicago Botanic Garden and AABGA will organize a two-day meeting with all project participants to articulate the process, expectations, and the people involved. The computer technician will confirm equipment needs at this time. Phase I participants will meet the second day when they will begin the work of defining the federation schema. Project partners will distribute research assignments to Phase I participants to ensure that information critical to the project's many audiences are included in *PlantCollections*. Each Phase I participant will contact approximately four members of a potential audience (taxonomists, weed scientists, etc.) and determine the three to four fields of information most critical or useful to their research or daily operations. Follow-up communication will be electronic.

Definition of the federation schema is likely to comprise the majority of activity in the first year. Three fields have been identified as a minimum data set each institution will offer. It is anticipated that each site will offer between seven and 13 data fields. Minimum fields are:

- Scientific Name: Permits plants to be cataloged and are universally recognized.
- Accession Number: Assigned to plants entering a collection based upon their scientific name, their origin, and the date of acceptance. They serve to define collections from different sources from each other when the taxa names are the same. Requests for germplasm are typically identified by scientific name and accession number.
- Wild Collected Status: Identifies an accession origin to a naturally occurring population and is of significant interest to many of the audiences. The location of wild populations of threatened or endangered plant species will not be disclosed.

Website Portal Design

AABGA will be responsible for the website portal design, hosting, and maintenance. A consultant will be hired to develop the information architecture as well as the graphic design

and layout. AABGA will continue to host and maintain the website through the life of the grant and beyond.

Software Modifications

Approximately one third of the living plant collections community uses a proprietary database management system (BGBase) for maintenance and curation of their collection data. Supporting this proprietary system requires the development of either a driver for DiGIR data providers that supports the BGBase systems, or perhaps more favorably, the export of data from BGBase to another system. DiGIR experts at BRC and BGBase consultants have agreed to collaborate and have submitted budget estimates to develop the optimum system for institutions using the BGBase system.

Scientific Names

A key impediment to sharing information in the living plant community is the problem of taxonomic discrepancies between scientific names used at different collections, and how they change over time, especially cultivar names. Because scientific names are one of the keys typically used for searching and locating records, this variability both within and between collections is a significant barrier to effective sharing of information. Taxon Authority files exist or are being created for naturally occurring taxa. One of the major objectives for *PlantCollections* is to develop a similar Taxon Authority file that includes cultivars.

PlantCollections will investigate a mechanism to search across biocollections data for taxonomic concepts instead of taxonomic names as a means to solving the question of cultivar taxonomy. One innovative solution for species names is being developed as part of a separate project—SEEK—which is implementing a taxonomic concept resolution service. In the late stages of development, SEEK will likely provide a powerful service for the living plant community and may also be readily adaptable to fit the requirements of this project. The SEEK Taxonomic Name Service is based on standards being defined by other groups that represents a consensus of the taxonomic community for naturally occurring (not of cultivated origin) plants.

Installation and Testing

The Chicago Botanic Garden will hire and house a full-time computer technician to assist the project over the life of the grant. The computer technician will be trained in the DiGIR application system at the Biodiversity Research Center at the University of Kansas. He will assist with the federation schema and work with the DiGIR developer to modify the application. The technology expert will spend two to three days at each participating institution to install and configure the data provider hardware and software. Installation and testing in Phase I will focus first on the Chicago Botanic Garden and Mt. Cuba Center, Inc., representing different database applications. Once these two sites are functioning, installation and testing will continue at The Huntington, Missouri Botanic Garden, The Morton Arboretum, and the United States National Arboretum.

Project partners anticipate that major issues and questions will emerge and be addressed in Phase I, including reaching consensus on data fields and characteristics, assessing the best method for connecting to DiGIR within each institution's existing technology, security of institutional data, and maintaining the technology. Project staff expect most institutions will mirror their data records, rather than allow access to original data, and the read-only status

of the DiGIR application will further protect information. Protection of threatened or endangered plants will be of paramount concern, and no locations will be identified.

Phase II

Once the major language and technological issues have been identified and addressed, *PlantCollections* will be installed in Phase II participating institutions. As reflected in the table below, Phase II institutions include smaller institutions with less technology support, which raises additional questions: 1) What, if any, considerations need to be addressed for small institutions with weak technology support? and 2) What maintenance issues and training requirements emerge? DiGIR will be modified, as needed to address these questions.

Table 3.

| Institution | Location | Size (Opr. Budget)* | Database | Tech. Support Level |
|--|-------------------|---------------------|-----------------------|---------------------|
| Arnold Arboretum, Harvard University | Cambridge, MA | Large | BG-Base 6.4 | Strong |
| Highstead Arboretum | Redding, CT | Small | Converting to Melange | Medium, contractor |
| Landis Arboretum | Esperance, NY | Small | BG-Base 4.0 | Weak, volunteer |
| Norfolk Botanical Garden | Norfolk, VA | Large | BG-Base 6.4 | Medium, contractor |
| The North Carolina Arboretum, University of North Carolina | Ashville, NC | Large | BG-Base 6.4 | Medium, contractor |
| Santa Barbara Botanic Garden | Santa Barbara, CA | Mid-Size | Access 2002 | Medium, contractor |
| San Francisco Botanical Garden | San Francisco | Small | FoxPro | Weak |
| Scott Arboretum, Swarthmore College | Swarthmore, PA | Small | BG-Base 6.4 | Strong |
| Washington Park Arboretum | Seattle, WA | Mid-Size | BG-Base | Strong |

*Annual operating budget key: Large >\$2 million; Mid-size between \$1-2 million; Small <\$1 million

The technician will continue to install hardware and software for Phase II institutions. The mix of large, mid-size, and small institutions that characterize Phase II will allow project staff to discern any necessary variations due to size of institution and level of IT support.

Training

Training is a critical component of the *PlantCollections* project and has been integrated into the design. The computer technician is scheduled to spend two to three days in each location with follow-up visits as necessary. Training local staff in maintaining the system is part of the computer technician's responsibility. Other training or discussion opportunities include sessions at AABGA national conferences as well as four meetings held regionally

across the U.S. Additionally, three DiGIR experts at the Biodiversity Research Center will be available for support services throughout the life of the grant. *PlantCollections* project staff will develop a training protocol, available on the AABGA website and updated as necessary, for institutions joining the project in subsequent years.

Communication

Once the DiGIR application has been successfully tested, the Chicago Botanic Garden and AABGA will develop and implement a communications strategy to announce the project to the botanic garden and arboreta community as well as other interested and potential audiences. Likely strategies are outlined on page ten.

Evaluation

PlantCollections will have a significant long-term impact on the way botanic garden and arboreta carry out the primary institutional purpose of collecting, studying and conserving living plants. The intended short-term change that the evaluation will address is *PlantCollections*' functionality: Does it speed access to plant information at the participating institutions for all interested audiences? Project evaluation in *PlantCollections*' first three years will focus on functionality and the ability of institutions of all sizes and with different types of database systems to share resources through the modified DiGIR application. Results of this ongoing evaluation will provide a continuous communication loop to modify DiGIR to better fit the needs of botanic gardens and arboreta. Through data collected at the Web portal, project partners will discover by whom the data is being accessed and assess its early impact on the work of its intended audiences.

Evaluation for *PlantCollections* will be integrated into the project design. Measurement methods to be utilized include reports generated by *PlantCollections*, work products, informal pre- and post-project surveys and focus group discussion to determine changes in the way participants and potential audiences secure information as a result of their access to *PlantCollections*. The initial Phase I meeting of participants will also serve as a focus group to discuss not only the federation schema but also determine how participants currently secure similar information. Assignments given to Phase I participants to interview three to four members of a particular audience will include similar questions. Phase II participants will contribute the same information in a written survey. Post-project surveys of participants and previously interviewed audience members will ask questions about ease of access to quality information, and will include questions as to how the information is being used and by whom. The following outcomes are expected:

1. Outcome: After three years, interested audiences will have easy access to plant records at participating institutions
Measures: Reports generated from *PlantCollections*
Pre-and post-project surveys
User testing with think-aloud protocols during the development of the site
2. Outcome: After three years, project partners will have documented protocols to train new project participants in system maintenance
Measures: Tested and posted website documents
Training sessions at regional and/or national AABGA conferences

3. Outcome: After three years, participating institutions and interested audiences are using *PlantCollections* in their work

Measures: Post-project surveys

Reports and work products (plants and germplasm secured; reports on studies, etc.)

PlantCollections is intended to bring into circulation the existing knowledge of living plants as represented in the documented records of botanic gardens and arboreta. Long-term, this tool carries a powerful potential to advance many scientific disciplines, especially influencing the development of botanic gardens and arboreta as sanctuaries for threatened and endangered plant species. Without this communication tool, the process of locating plants and germplasm will continue to be cumbersome and time-consuming; gaps in germplasm collections will go unnoticed, contributing to species extinction; and unnecessary disruptions of plants *in situ* will prevail.

4. Project Resources: Budget, Personnel, and Management Plan

PlantCollections represents the collective vision of the Chicago Botanic Garden, the AABGA, and the Biodiversity Research Center at the University of Kansas. Project roles and responsibilities are as follows:

Chicago Botanic Garden: The Chicago Botanic Garden will administer the grant proposal, submit reports, perform accounting functions and dispersal of funds, manage the technician, schedule and manage the installation of hardware and software applications for each participant, host meetings, and create a listserv to provide timely information exchange to all participants.

American Association of Botanical Gardens and Arboreta (AABGA): As the managing authority for the North American Plant Collections Consortium, AABGA will advocate for project participation and communicate information to the national membership. Communication between the NAPCC coordinator and Chicago Botanic Garden staff will be regular and consistent. AABGA will be responsible for organizing major meetings of participants, including project development and training. AABGA will host the initial *PlantCollections* website portal and will participate in a communications strategy to announce its availability.

Biodiversity Research Center, University of Kansas: The Biodiversity Research Center will assist with training the full time technician hired through this grant, supplying the software, and recommending hardware. They will provide assistance and expert advice to ensure success of the project. Communication with DiGIR developers at the BRC is available throughout the life of the grant. BRC will provide access to expertise to assist with deployment, configuration, and modifications.

Principal staff members guiding the project include the following people from the Chicago Botanic Garden and AABGA. A job description for the computer technician and brief resumes are attached.

Dr. Christopher P. Dunn, executive director, scientific affairs, Chicago Botanic Garden will serve as a co-director of the project with Mr. Tankersley. Dr. Dunn brings significant

experience to this project from his work as principal investigator for an NSF grant for modernization of The Morton Arboretum's herbarium, as project director for the IMLS-funded *vPlants*, and as a member of the AABGA Board of Directors. He will participate in developing the federation schema and oversee project development. He has 10 years of experience in public garden administration and 25 years of research experience in ecology and conservation.

Boyce Tankersley, manager, living plant documentation, Chicago Botanic Garden will serve as a co-director of the *PlantCollections* project. He will supervise the computer technician, coordinate logistical aspects of project development, and participate in developing the federation schema. Mr. Tankersley has 13 years experience at public gardens and serves as chair of AABGA's Information Technology Committee.

Pamela Allenstein, coordinator, North American Plant Collections Consortium, AABGA will assist with communications, work with website designers, and coordinate training sessions at national conferences and regional meetings. She brings 10 years experience in public gardens and four years at AABGA to this project.

Daniel J. Stark, executive director, AABGA will oversee the project and assist with communication to the organization's national membership as necessary. Mr. Stark will be responsible for selecting and overseeing the work of the website designers and the maintenance of the website portal.

Dr. David Viegla

Dr. David Viegla is a Senior Scientist and Research Associate at the Biodiversity Research Center at the University of Kansas and developer of DiGIR. Dr. Viegla has been consulting with the Chicago Botanic Garden and AABGA in the project's development and will continue to act as primary consultant during the grant period. He will be responsible for working with Phase I participants to achieve the federation schema and for modifying and customizing the DiGIR application for *PlantCollections*. While Dr. Viegla will support project partners, three DiGIR experts at the University of Kansas will support participating institutions for three years.

Funds requested are for direct costs only, including consultant fees, equipment, the computer technician's salary, and travel. All institutions are contributing staff time and indirect costs.

5. Dissemination

PlantCollections will enjoy the benefit of multiple partners or stakeholders in its promotion. Responsibility for disseminating information about *PlantCollections* will lie with the primary partners: AABGA and the Chicago Botanic Garden, with the 16 participating organizations encouraged to communicate its availability to their local constituencies. The major message of a communication strategy will be to announce the opportunity and outline its potential applications. Messages can be generalized or tailored to the particular audience addressed. Communication vehicles are outlined below.

AABGA

- Article in *Public Garden* and announcement in AABGA newsletter (circulation 1,700 subscribers)

- Announcement on AABGA website (approximately 1 million hits per year)
- Verbal presentations, demonstrations, and/or informational display at national AABGA conferences, regional meetings (approximately 860 attendees)
- Presentations and demonstrations at national conferences of targeted audiences, as well as the American Association of Museum, National Library Association, Museum Computer Network

Chicago Botanic Garden

- Announcement on website (approximately 5,340,600 hits per year)
- Article in *Garden Talk* newsletter (46,000 members)
- Press releases (list of 400 editors in print nationwide media)
- Verbal and poster presentations and demonstrations at select Chicago Botanic Garden symposia

Participating Institutions

- Announcement on website
- Other local vehicles selected by institution

6. Sustainability

Project partners are mindful of the challenges involved in developing and maintaining a searchable database system linked to a large number of organizations with varying databases and levels of institutional technical support. However, as previously noted by Stein and Wieczorek, the DiGIR application has a reputation for simplicity and relative low cost—two principal reasons for its selection for this project. Project partners believe that success in achieving functionality will attract additional institutions (as has been the case with *vPlants*), and a collective recognition of *PlantCollections*' value will help ensure its future.

AABGA recognizes its significant role in maintaining *PlantCollections* beyond the life of the grant. By sustaining *PlantCollections*, AABGA strengthens its position as a national service organization of botanic gardens and arboreta. In fact, AABGA has identified its website as an important part of their future for communication, expansion, and management of its membership. In turn, *PlantCollections* will benefit from AABGA's role as convener. AABGA's national conferences and regional meetings offer a chance to sustain and strengthen the partnership through continued discussion of issues as well as training in DiGIR maintenance. Regular opportunities for colleagues to discuss *PlantCollections* and its potential applications will contribute to its use as a vital tool for managing plant collections and conducting collaborative research.

An IMLS National Leadership grant will provide valuable funding to assist *PlantCollections* in its early incubation stages. Project partners intend to pursue other sources of private and public support to assist the project and broaden future participation.

Literature Cited

Alberch, P. 1993. Museums, collections and biodiversity inventories. *Trends in Ecology and Evolution* 8: 372-375.

Dalton, R. 1999. US universities find that demand for botanists exceeds supply. *Nature* 402: 109-110.

Dunn, C.P. 2002. Innovative conservation partnerships among botanical gardens. Restoration of Disturbed Natural Ecosystems; Proceedings of the First International Conference. Donetsk Botanical Garden, Donetsk, Ukraine.

Schaub, M., and C.P. Dunn. 2002. vPlants: a virtual herbarium of the Chicago region. First Monday issue 7 (www.firstmonday.dk)

Phase 1 Partnership Statement

January 24, 2005

1. Applicant Organization:
Chicago Horticultural Society

Other partner members (organizations):

American Association of Botanic Gardens and Arboreta

Phase 1 partners

Chicago Botanic Garden

Ganna Walska Lotusland

Huntington Library, Museum and Botanic Garden

Mt. Cuba Center for the Study of Piedmont Flora

The Morton Arboretum

Missouri Botanic Garden

United States National Arboretum

Phase 2 partners

Arnold Arboretum of the Harvard University

Highstead Arboretum

Landis Arboretum

Norfolk Botanic Garden

North Carolina Arboretum

San Francisco Botanical Garden

Santa Barbara Botanic Garden

Scott Arboretum of Swarthmore College

Washington Park Arboretum

Biodiversity Research Center, University of Kansas

2. Briefly list the activities that each organization has agreed to perform:

Chicago Horticultural Society (Chicago Botanic Garden or CBG)

As principal investigator, the Chicago Botanic Garden will administer the grant proposal submittal, submit reports, perform accounting functions related to the grant including dispersal of funds, manage the grant funded temporary employee, schedule and manage the installation of hardware and software applications for each participant, act as liaison with the BRC and consultants, create listserv to provide timely information exchange to all participants.

American Association of Botanic Gardens and Arboreta (AABGA)

As the managing authority for the North American Plant Collections Consortium (NAPCC), AABGA advocates for participation in the grant, acts as a conduit of information and provides opportunities for sharing progress reports with the national membership for this project. The NAPCC coordinator and AABGA Executive Director are actively involved in recruiting NAPCC institutions, providing insight into NAPCC institutional capabilities and assisting the PI with timeliness of submittals and work schedules. Introduction of the grant proposal to the NAPCC membership is through the NAPCC Coordinator (curatorial level) and AABGA Executive Director (institutional director level). Communication between the NAPCC Coordinator and the CBG PI is regular and consistent. Using temporary full time staff hired through this grant, AABGA is primarily responsible for the designing a website environment suitable to host the portal through which information is disseminated.

Biodiversity Research Center, University of Kansas

BRC will assist with training the full time technician hired through this grant, supplying software and recommending hardware. They provide assistance and expert advice to ensure success of the project. Communication with DiGIR developers at BRC is available throughout the life of the grant. NOTE: The BRC can not enter into a contractual obligation to support this protocol as resources are not available. BRC can provide access to expertise to assist with deployment, configuration, and modifications, however the primary source of this form of assistance is through the fora available through the DiGIR project's source forge presence.

(Participant Garden Name)

Agrees to participate in the following activities and to work towards the successful and timely completion of all grant objectives to include but not limited to:

- Identify an institutional contact for the grant associated with this work and provide contact information to include but not be limited to name, title, telephone, fax, email, mailing address.
- Attend at least one (maybe more) meetings (paid for by grant funds 1-2 days),
- Participate in some conference calls (weekly),
- Budget time for emailed questions between Phase 1 participants.
- Budget staff time to work with the technician hired by this grant to 'map' the institutions' database field names and definitions to the field names and definitions used at the AABGA portal.
- Understanding that, the more data that is shared, the more time will be invested. Previous DiGIR installation experience indicates a typical duration of 1-3 days depending on the complexity and type of system being configured.
- Budget staff time before the technician arrives to have as much information as possible available for them. (i.e. what fields to share with the portal, field name, size, definition, other characteristics, etc.).
- Keep Information Technology staff (and or your Web Master) involved in the evolution of the project to facilitate installation of the software application – and budget time for them. They will need to provide computer access, including temporary administrative rights to enable the technician to install software (and in some cases hardware).
- Budget time within your institution to hold meetings to discuss what information will be offered to the portal, in addition to the minimum 3 fields (scientific name, accession number, wild collected status).
- Document and submit staff time spent on the project and invoices for grant-covered costs incurred.

3. We, the undersigned institutions, agree to all of the following:

- We will carry out the activities described above and in the Application Narrative;
- We will use any funds we receive from IMLS in accordance with applicable federal laws and regulations; and
- We assure that our facilities and programs comply with applicable federal requirements.

Signature of Authorizing Official

Partner Organization (Type or Print)

Name of Authorizing Official (Type or Print)

Date

Phase 2 Partnership Statement

January 24, 2005

1. Applicant Organization:
Chicago Horticultural Society

Other partner members (organizations):

American Association of Botanic Gardens and Arboreta

Phase 1 partners

Chicago Botanic Garden

Ganna Walska Lotusland

Huntington Library, Museum and Botanic Garden

Mt. Cuba Center for the Study of Piedmont Flora

The Morton Arboretum

Missouri Botanical Garden

United States National Arboretum

Phase 2 partners

Arnold Arboretum of the Harvard University

Highstead Arboretum

Landis Arboretum

Norfolk Botanic Garden

North Carolina Arboretum

San Francisco Botanical Garden

Santa Barbara Botanic Garden

Scott Arboretum of Swarthmore College

Washington Park Arboretum

Biodiversity Research Center, University of Kansas

2. Briefly list the activities that each organization has agreed to perform:

Chicago Horticultural Society (Chicago Botanic Garden or CBG)

As principal investigator, the Chicago Botanic Garden will administer the grant proposal submittal, submit reports, perform accounting functions related to the grant including dispersal of funds, manage the grant funded temporary employee, schedule and manage the installation of hardware and software applications for each participant, act as liaison with the BRC and consultants, create listserv to provide timely information exchange to all participants.

American Association of Botanic Gardens and Arboreta (AABGA)

As the managing authority for the North American Plant Collections Consortium (NAPCC), AABGA advocates for participation in the grant, acts as a conduit of information and provides opportunities for sharing progress reports with the national membership for this project. The NAPCC coordinator and AABGA Executive Director are actively involved in recruiting NAPCC institutions, providing insight into NAPCC institutional capabilities and assisting the PI with timeliness of submittals and work schedules. Introduction of the grant proposal to the NAPCC membership is through the NAPCC Coordinator (curatorial level) and AABGA Executive Director (institutional director level). Communication between the NAPCC Coordinator and the CBG PI is regular and consistent. Using temporary full time staff hired through this grant, AABGA is primarily responsible for the designing a website environment suitable to host the portal through which information is disseminated.

Biodiversity Research Center, University of Kansas

BRC will assist with training the full time technician hired through this grant, supplying software and recommending hardware. They provide assistance and expert advice to ensure success of the project. Communication with DiGIR developers at BRC is available throughout the life of the grant. NOTE: The BRC can not enter into a contractual obligation to support this protocol as resources are not available. BRC can provide access to expertise to assist with deployment, configuration, and modifications, however the primary source of this form of assistance is through the fora available through the DiGIR project's source forge presence.

(Participant Garden Name)

Agrees to participate in the following activities and to work towards the successful and timely completion of all grant objectives to include but not limited to:

- Budget staff time to work with the technician hired by this grant to 'map' the institutions' database field names and definitions to the field names and definitions used at the AABGA portal.
- Understanding that, the more data that is shared, the more time will be invested. Previous DiGIR installation experience indicates a typical duration of 1-3 days depending on the complexity and type of system being configured.
- Budget staff time before the technician arrives to have as much information as possible available for them. (i.e. what fields to share with the portal, field name, size, definition, other characteristics, etc.).
- Keep Information Technology staff (and or your Web Master) involved in the evolution of the project to facilitate installation of the software application – and budget time for them. They will need to provide computer access, including temporary administrative rights to enable the technician to install software (and in some cases hardware).
- Budget time within your institution to hold meetings to discuss what information will be offered to the portal, in addition to the minimum 3 fields (scientific name, accession number, wild collected status).
- Document and submit staff time spent on the project and invoices for grant-covered costs incurred.

3. We, the undersigned institutions, agree to all of the following:

- We will carry out the activities described above and in the Application Narrative;
- We will use any funds we receive from IMLS in accordance with applicable federal laws and regulations; and
- We assure that our facilities and programs comply with applicable federal requirements.

Signature of Authorizing Official

Partner Organization (Type or Print)

Name of Authorizing Official (Type or Print) Date